

“!\$\$\$\$-\$.\$, @\$ (e\$S

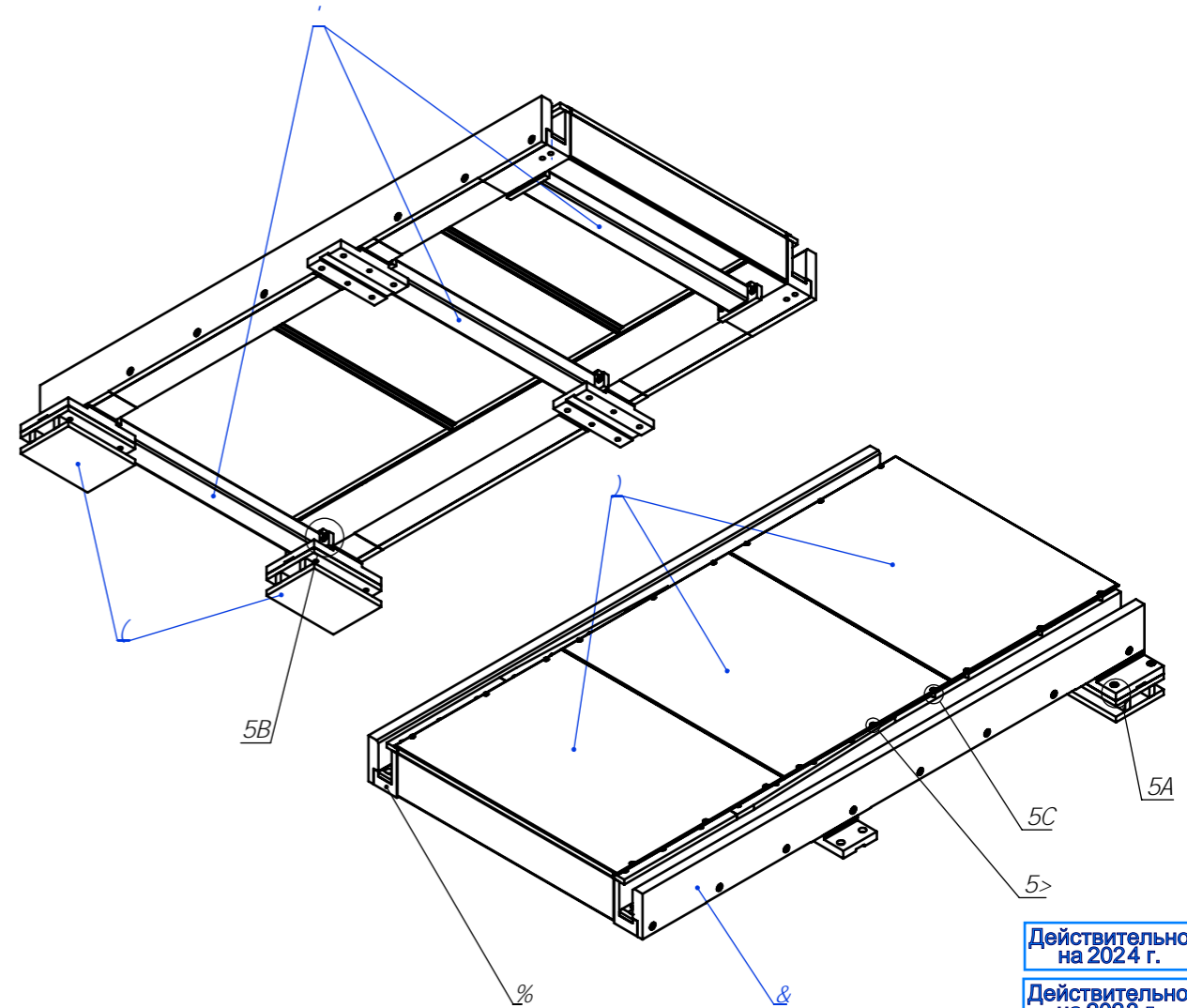
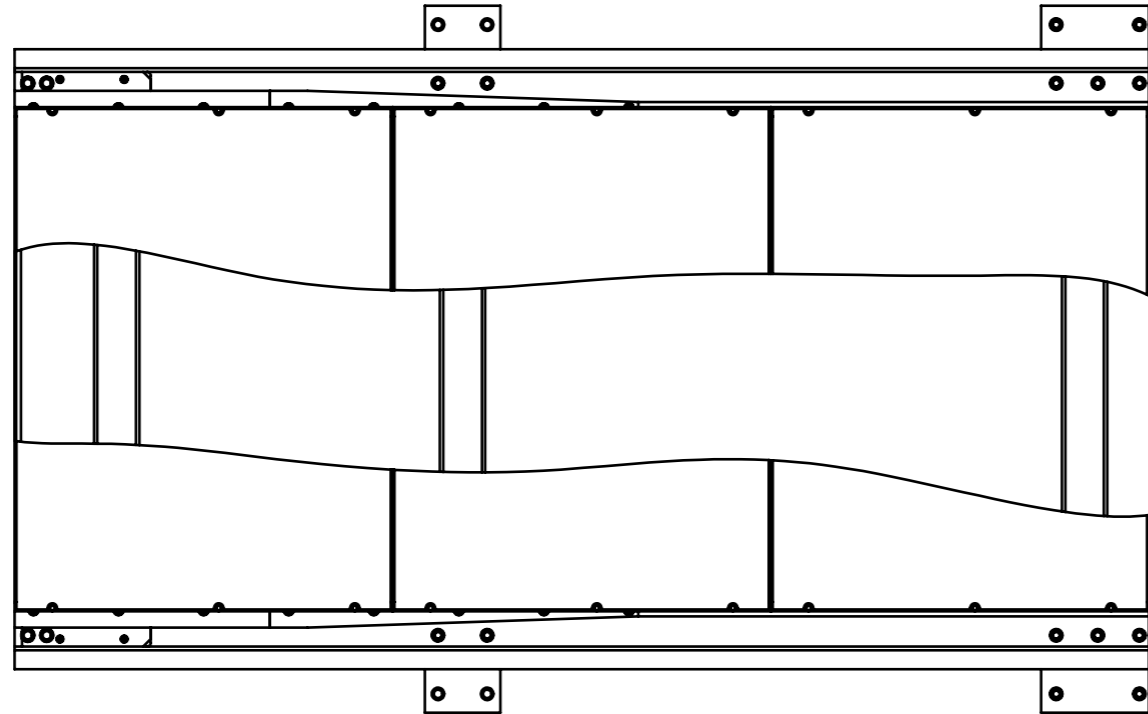
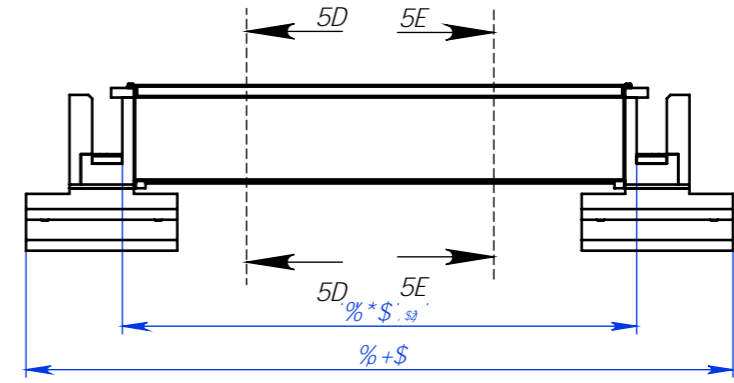
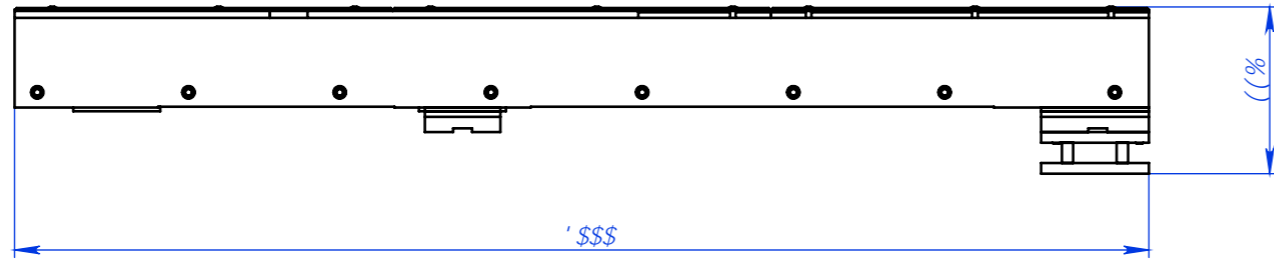

Действительно на 2024 г.

Действительно на 2023 г.

Действительно на 2022 г.

% ¥LVA°AD'AOAÄÄ; Ä;

пА/4	Е/А/А/и °А/2	пА/А°/иА/2	оАА"	"°Е	и μС°А/рА
%	Soe) \$@' S' \$- %\$\$\$ ¥°ÄÑEÄÄ½ÄÄD¾		%	+&-	
&	Soe) \$@' S' \$- &\$\$\$ ¥°ÄÑEÄÄ½ÄÄD¾		%	+&-	
'	Soe) \$@' j' \$' '\$\$\$ - ÇμÄ μ		'	&&²-	
(Soe) \$@' j' \$' ('\$\$\$ EÄÄÄμ		&	*\$**	
)	Soe) \$@' j' \$')' '\$\$\$ оАД' μ		'	(+²-	
*	Soe) \$@' j' \$' '\$\$\$%Tμi ½μ		%)&*²	¡Ç' ÄE•E S", \$! - (
+	Soe) \$@' j' \$' '\$\$\$% ÇEÄÄμ		,	\$&&	¡ÇμÄÑ&\$ •E S %) \$! , ,
,	Soe) \$@' j' \$' '\$\$\$& оАÄÄ°ÄEÇÄÄ		'	\$Y(¡Ç' ÄE•E S", \$! - (
-	"VÄÇ' A&E) \$B- %	•E S' %%, !, (,		
%	"VÄÇ' A&E) \$B- %	•E S' %%, !, (%		
%	"VÄÇ' 5j' (!*ZK%, ")°\$& •E S' % (+!, \$	8B' +,)	(
%	"ÄÄÇ' j' !*ZK%-%-\$&*•E S+ \$) !+\$	8B' -' %	%		
%	"ÄÄÇ' j' !*ZK(\$%-\$&*•E S+ \$) !+\$	8B' -' %	,		
%	-μ³Äμ, "\$%, "\$% •E S' % + % +,	8B' %&) 5	%		

				Soe) \$@' S' \$- '\$\$\$\$!		
Y/Ç"	i LVAE	i LVAE ÇμÄ				
	%\$'	%\$				
Y/ÇC %	Y/ÇCÄ	2				
			'S°E¡ÇÄÄ¾			

&& ÄEÄÇÄÄ°Ä&\$% , ", .) *.) ("BP&\$%SSoe) \$@' SSGK %P¡ÄÄ; μPSoe) \$@' S' \$- '\$\$\$\$ ¥°ÄÑEÄÄ D¾ÄÄÄ;

„/\$\$\$\$-\$ \$, @\$ (∞\$

1-→ \$-5D! 5D'
i'|-S' " % %&

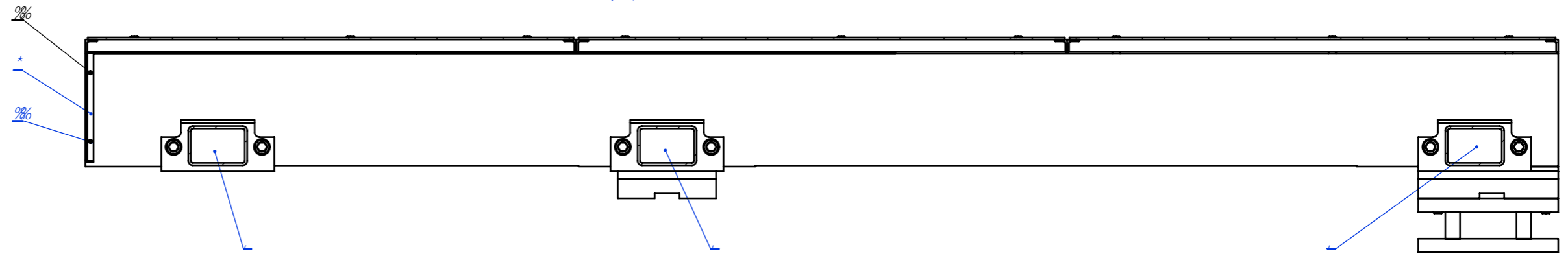

1-→ \$-5E! 5E'
i'|-S' " % %&

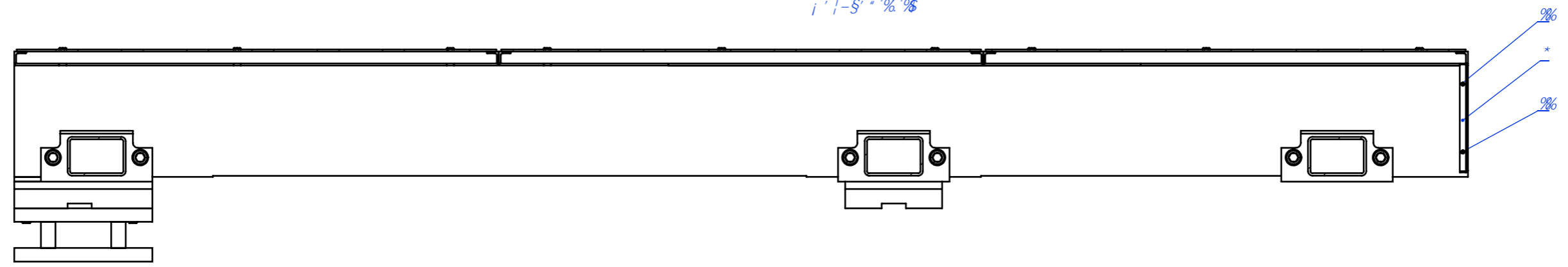

i +Sc° > '5B'
i'|-S' " % &

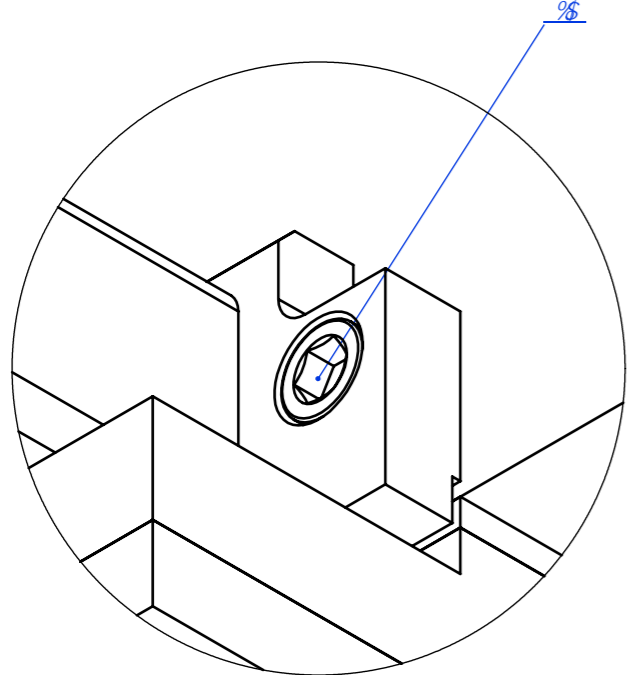

i +Sc° > '5C'

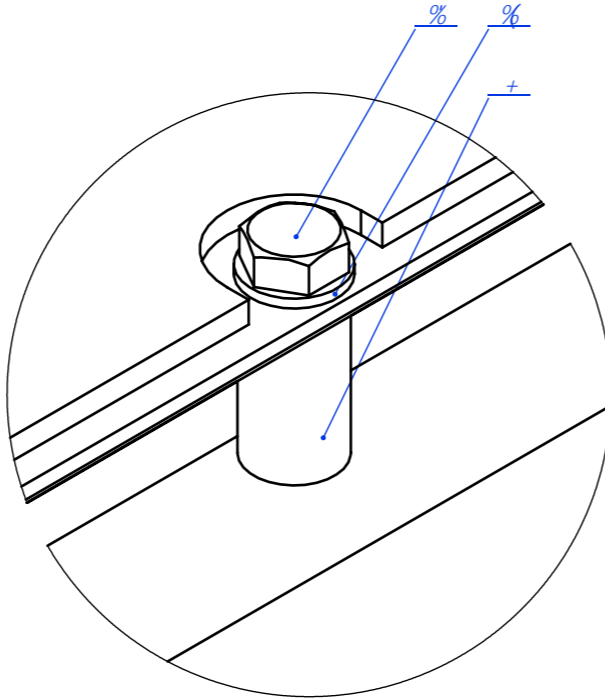

i +Sc° > '5A'
i'|-S' " % &

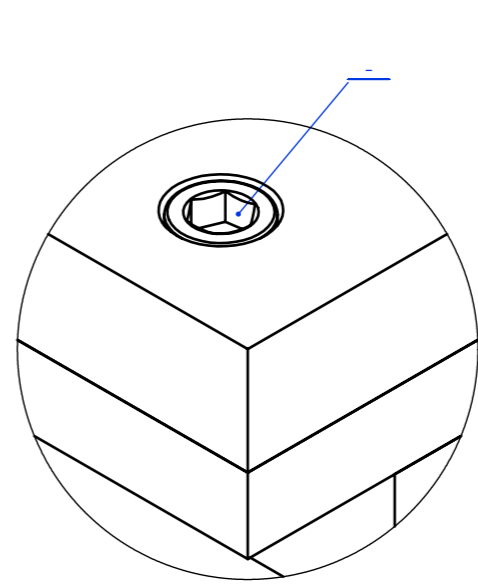

i +Sc° > '5>

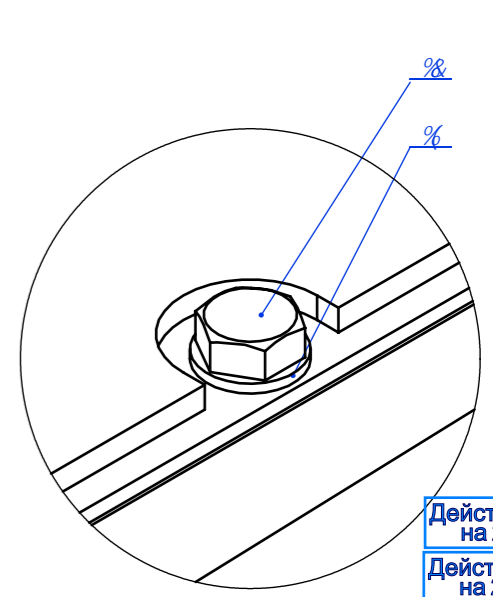

Действительно на 2024 г.
Действительно на 2023 г.
Действительно на 2022 г.

СА "B" АА"А"	ПА"А" 1/2" ЛУЧ
" 1/4" А" А" "B	СА "B" Е"А"
ПА"А" 1/2" ЛУЧ	СА "B" Е"А"
СА "B" АА"А"	ПА"А" 1/2" ЛУЧ

СА "B" АА"А"	ПА"А" 1/2" ЛУЧ	СА "B" Е"А"	ПА"А" 1/2" ЛУЧ
--------------	----------------	-------------	----------------

Sc°) \$@' \$ \$- '\$\$\$\$! "

Y 1/2
&