

НКТ052.01

√3.2(√)

Предельные отклонения для угловых размеров, мм. (ГОСТ 30893.1-2002) Класс точности средний (m)		до 10		св. 10 до 50		св. 50 до 120		св. 120 до 400		св. 400	
		± 1,0'		± 30'		± 20'		± 10'		± 5'	
Предельные отклонения для интервалов номинальных размеров, мм. (ГОСТ 30893.1-2002) Класс точности средний (m)		св. 3,0 до 6,0		св. 6,0 до 30		св. 30,0 до 120		св. 120 до 400		св. 400 до 1000	
		± 0,1		± 0,2		± 0,3		± 0,5		± 0,8	
от 0,5 до 3,0		± 0,1		± 0,2		± 0,3		± 0,5		± 0,8	
св. 3,0 до 6,0		± 0,1		± 0,2		± 0,3		± 0,5		± 0,8	
св. 6,0 до 30		± 0,2		± 0,3		± 0,5		± 0,8		± 1,2	
св. 30,0 до 120		± 0,3		± 0,5		± 0,8		± 1,2		± 2,0	
св. 120 до 400		± 0,5		± 0,8		± 1,2		± 2,0		± 3,0	
св. 400 до 1000		± 0,8		± 1,2		± 2,0		± 3,0		± 4,0	
св. 1000 до 2000		± 1,2		± 2,0		± 3,0		± 4,0		± 6,0	
св. 2000 до 4000		± 2,0		± 3,0		± 4,0		± 6,0		± 10,0	
св. 4000 до 6000		± 3,0		± 4,0		± 6,0		± 10,0		± 15,0	

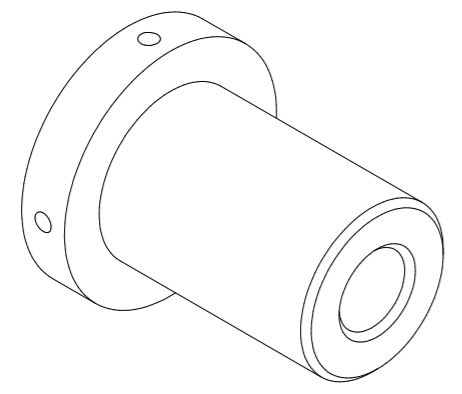
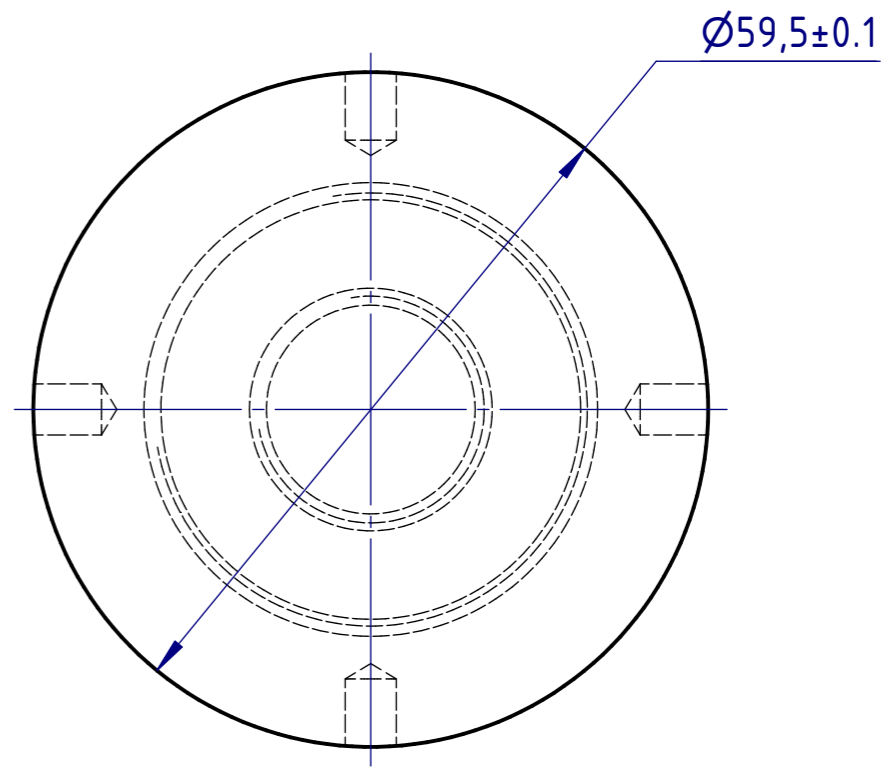
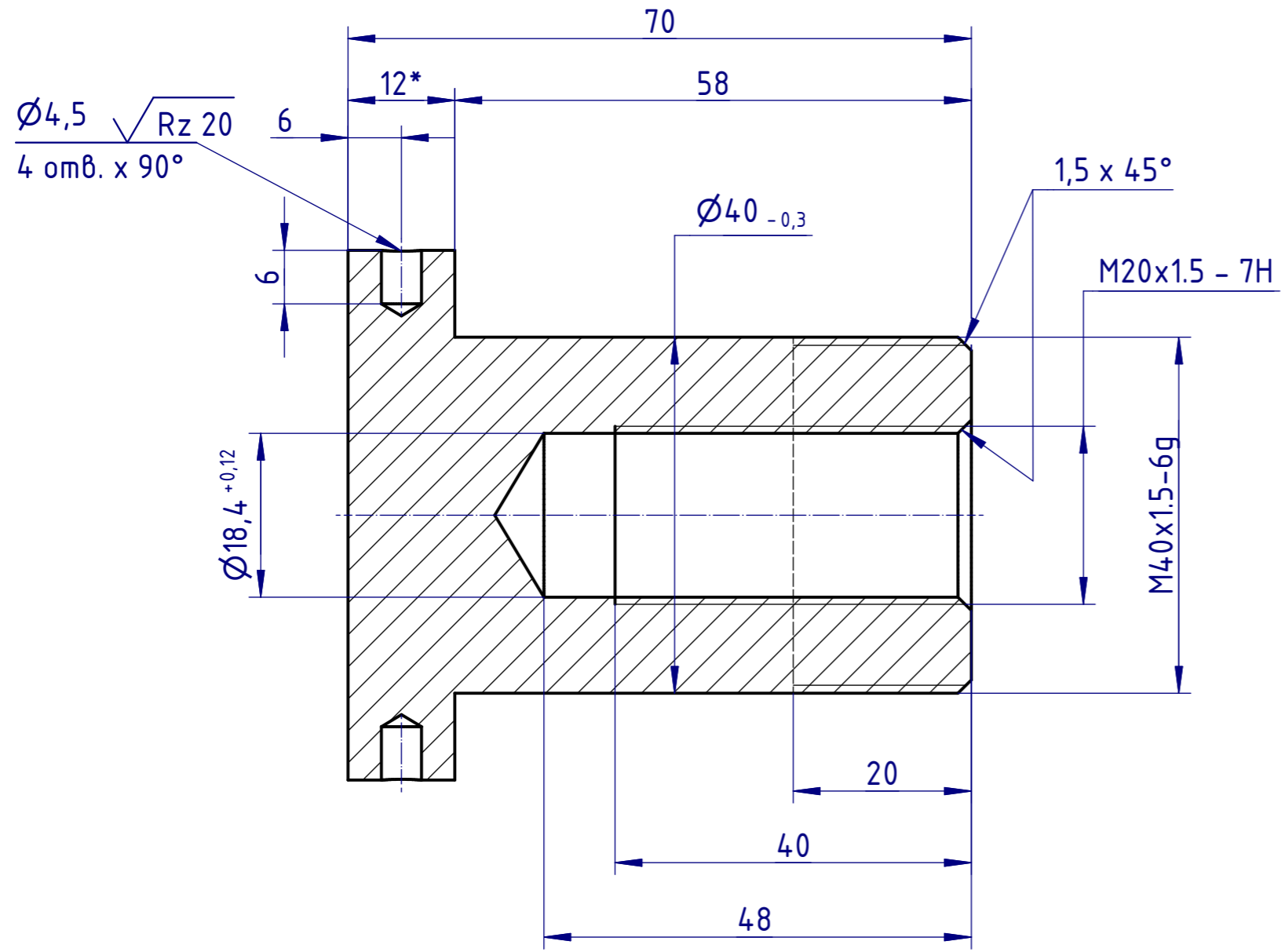

- *Размеры справочные.
- Общие допуски по ГОСТ 30893.1:H12, h12, ±IT12/2;

CAD: Втулка FAT1428-AA-2100.ipt				Изменен: 11.10.2023																																											
НКТ052.01																																															
<table border="1"> <tr> <td>Изм.</td> <td>Лист</td> <td>№ докум.</td> <td>Подп.</td> <td>Дата</td> </tr> <tr> <td>Разраб.</td> <td>Титов Г.С.</td> <td></td> <td></td> <td>11.10.2023</td> </tr> <tr> <td>Пров.</td> <td></td> <td></td> <td></td> <td></td> </tr> <tr> <td>Т. контр.</td> <td></td> <td></td> <td></td> <td></td> </tr> <tr> <td>Нач.отд.</td> <td></td> <td></td> <td></td> <td></td> </tr> <tr> <td>Н. контр.</td> <td></td> <td></td> <td></td> <td></td> </tr> <tr> <td>Утв.</td> <td></td> <td></td> <td></td> <td></td> </tr> </table>				Изм.	Лист	№ докум.	Подп.	Дата	Разраб.	Титов Г.С.			11.10.2023	Пров.					Т. контр.					Нач.отд.					Н. контр.					Утв.					Головка резьбовая		<table border="1"> <tr> <td>Лист</td> <td>Масса</td> <td>Масштаб</td> </tr> <tr> <td></td> <td>0,73</td> <td>1,5 : 1</td> </tr> </table>	Лист	Масса	Масштаб		0,73	1,5 : 1
				Изм.	Лист	№ докум.	Подп.	Дата																																							
Разраб.	Титов Г.С.			11.10.2023																																											
Пров.																																															
Т. контр.																																															
Нач.отд.																																															
Н. контр.																																															
Утв.																																															
Лист	Масса	Масштаб																																													
	0,73	1,5 : 1																																													
<table border="1"> <tr> <td>Лист</td> <td>Листов</td> <td>1</td> </tr> </table>				Лист	Листов	1	Круг $\frac{65-B1 \text{ ГОСТ } 2590-2006}{45 \text{ ГОСТ } 1050-2013}$																																								
				Лист	Листов	1																																									
Копировал		Формат А3																																													