

ITEM	QTY	DESCRIPTION	WT
1	1	92" OD STEAM DRUM - ASME CODE 3B-41157	15,289
2	256	3 1/4" OD TUBE X .120" WALL X 16'-6 3/4" SEE NOTE A	17,008
3	42	2" OD TUBE X .165" WALL 1B-40105	1178
4	40	2" OD TUBE X .165" WALL 1B-40106	1078
5	2	2" OD TUBE X .165" WALL 1B-40110	50
6	2	2" OD TUBE X .165" WALL 1B-40111	46
7	2	2" OD TUBE X .165" WALL 1B-40112	44
8	2	2" OD TUBE X .165" WALL 1B-40113	42
9	2	2" OD TUBE X .165" WALL 1B-40114	40
10	2	2" OD TUBE X .165" WALL 1B-40115	40
11	2	2" OD TUBE X .165" WALL 1B-40116	38
12	2	2" OD TUBE X .165" WALL 1B-40117	38
13	2	2" OD TUBE X .165" WALL 1B-40118	38
14	2	2" OD TUBE X .165" WALL X 5'-8 5/16"	37
15			
16	1R/1L	2" OD TUBE X .165" WALL 1B-40127	56
17	1R/1L	2" OD TUBE X .165" WALL 1B-40128	54
18	1R/1L	2" OD TUBE X .165" WALL 1B-40129	52
19	1R/1L	2" OD TUBE X .165" WALL 1B-40130	50
20	1R/1L	2" OD TUBE X .165" WALL 1B-40131	48
21	1R/1L	2" OD TUBE X .165" WALL 1B-40132	48
22	1R/1L	2" OD TUBE X .165" WALL 1B-40133	46
23	1R/1L	2" OD TUBE X .165" WALL 1B-40134	44
24	1R/1L	2" OD TUBE X .165" WALL 1B-40135	44
25	2	2" OD TUBE X .165" WALL 1B-40136	44
26	1	BOILER HEADER & FRAME ASSY 3B-49383	2381
27			
28	2	6" PIPE, SCH 40, BE, SA106-B X 6'-3"	238
29	2	6" ELBOW, 90°, SR, SCH 40, BE, SA234-WPB	33
30	4	FB 2" X 1/4" X 1'-5"	10
31	8	FB 1 1/2" X 1/4" X 1'-5"	15
32	1	1 1/2" CROSS, 3000#, THD, FS, A105	9
33	1	2" ELBOW, 90°, 3000#, THD, FS, A105	6
34			
35			

SEE CUT LIST PER DWG OB-41168

*FRAME NOT SHOWN FOR CLARITY

38,144#

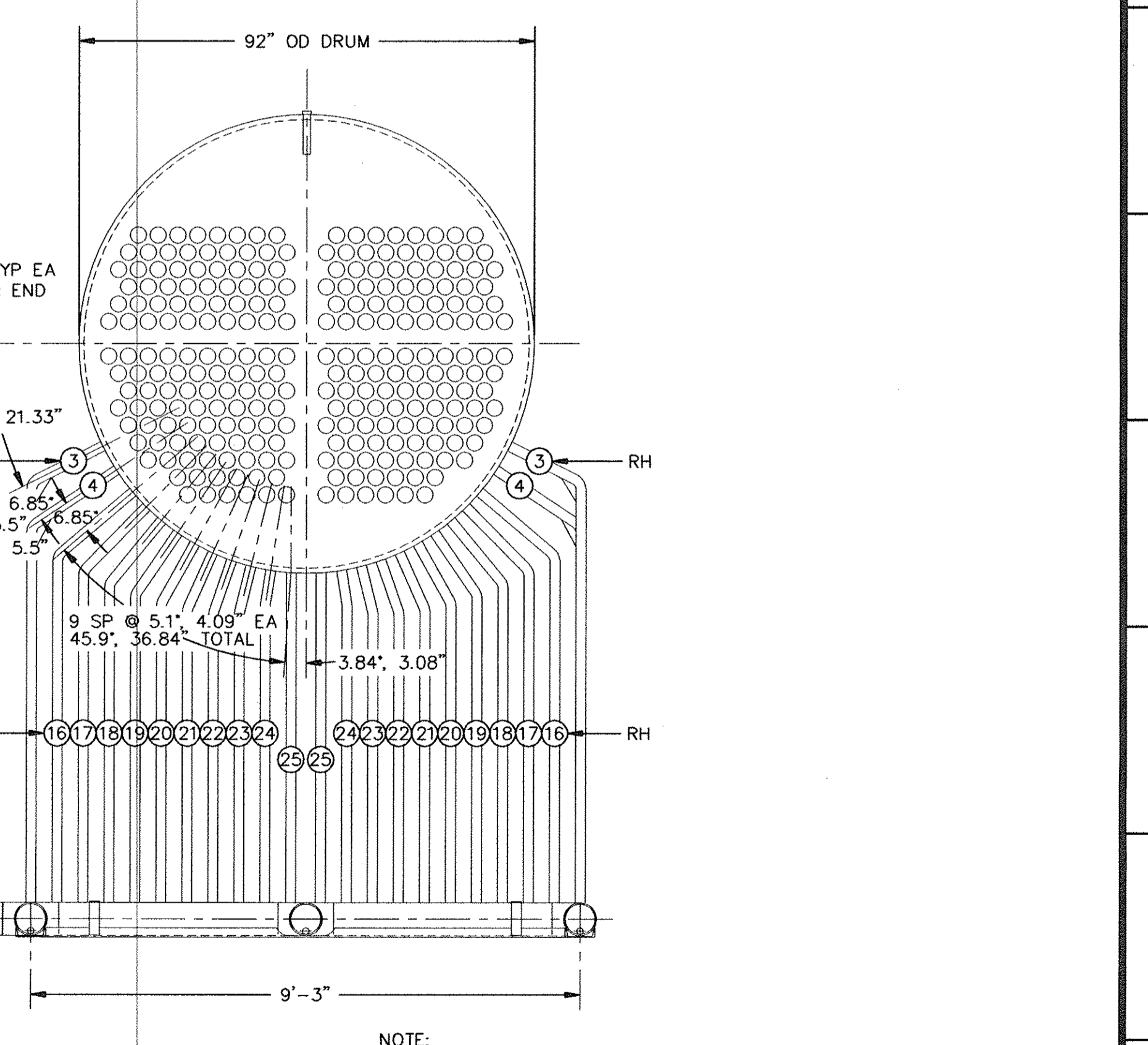

NOTE:
A. THE INDICATED TUBE LENGTH IS A NOMINAL DIMENSION. EACH TUBE SPACE SHOULD BE MEASURED BEFORE THE TUBE IS CUT TO LENGTH TO INSURE PROPER FIT-UP (SEE SECT C-C).

NOTES:
1. CONSTRUCT TO ASME CODE SECTION 1 19___ ADDENDA 19___
2. DESIGN PRESSURE: 200 PSIG
DESIGN TEMPERATURE: 400° F
HYDROTEST PRESSURE: 300 PSIG
3. ALL FLANGE BOLT HOLES TO STRADDLE CL'S.

19___ EDITION, 19___ ADDENDA
APPROVED BY: _____ DATE: _____

REV.		DATE	REVISION	BY	600 HP/200 PSIG	DRAWING NUMBER	REV.
						3B-49382	

WELLONS P.O. BOX 1030 SHERWOOD, OR 97140-1030

SCALE 1/2" = 1'-0" APPROVED BY: [Signature] DRAWN BY: [Signature] CHECKED BY: [Signature]

DATE 9/9/96 DO NOT SCALE THIS DRAWING

BOILER PRESSURE PARTS ASSEMBLY ASME CODE

FROM 3B-46388