

MATERIAL: TUNGSTEN CARBIDE CERATIZIT GRADE CTM17E

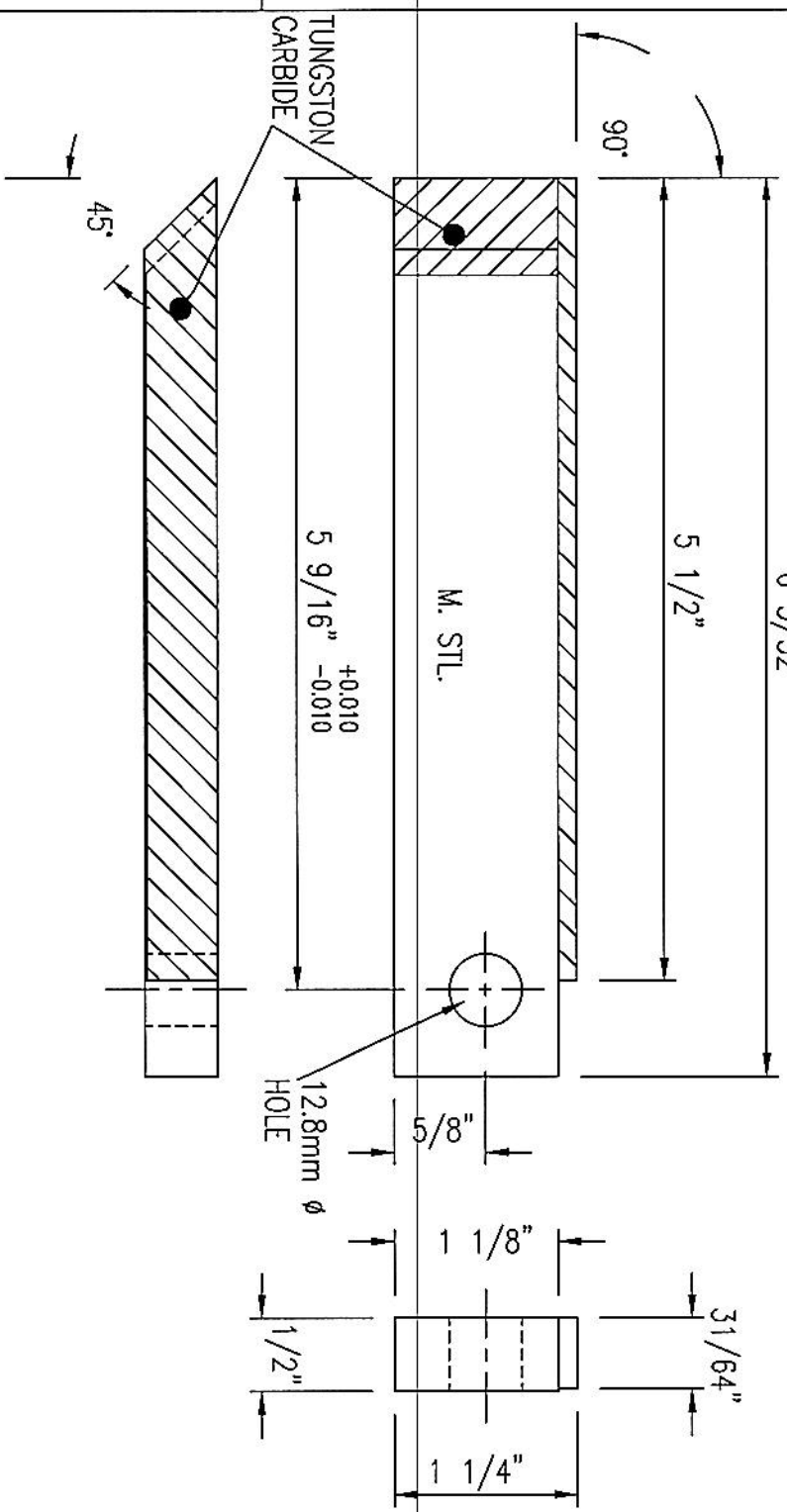

GENERAL NOTES:-
 T.C. TO BE SILVER SOLDERED TO M. STL.
 TINES TO BE BALANCED IN PAIRS TO WITHIN 0.5 grms.
 SETS (18 PAIRS) TO BE BALANCED TO WITHIN 4 grms.
 BALANCED PAIRS TO BE WIRED TOGETHER.
 ALL TINES TO BE CLEARLY MARKED WITH IDENTIFICATION CODE.

ECCI STORES Pt. No. 27/92065

MOD	DATE	MODIFICATION
2	3/8/06	GC15 CHANGED TO CTF24E
3	22/11/11	CTF24E CHANGED TO CTM17E

D.O. REF:
 F:\PRODENG\DATA CAD\BUYING\MECHANIC\0004A2
 F:\PRODENG\DATA CAD\BUYING\LOTFILE\L52942

DRAWN BY A.C. ROWE DATE 17/09/97	ORIGINAL SCALE/FRACTION DO NOT SCALE	PROJ NO	TITLE CLASSIFIER TINES. (MATCHED SET OF 18 PAIRS) WITH CARBIDE EDGE & TIP
	[REDACTED]		DRG NO C52942-3