

„!\$\$\$\$*\$!,©\$(∞\$

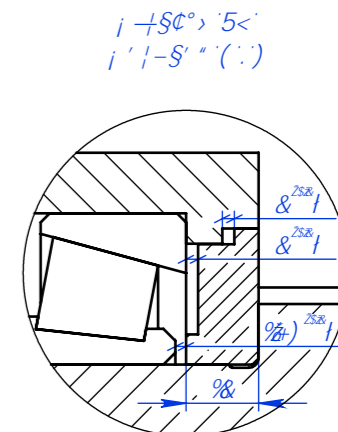
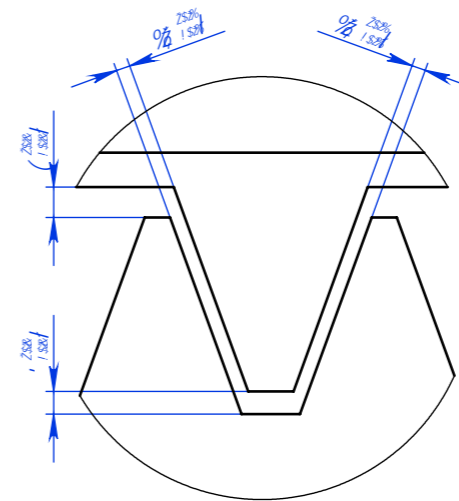
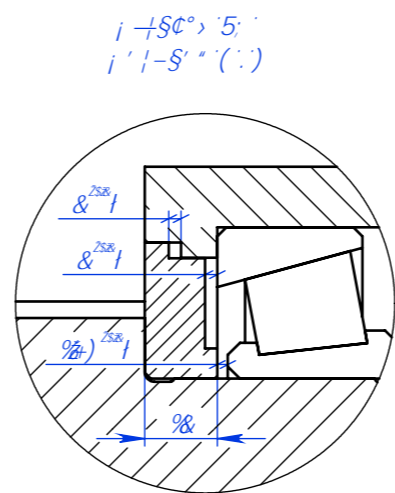
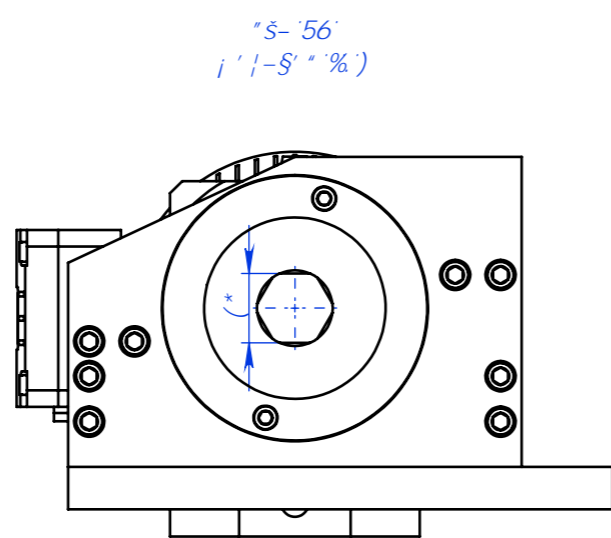
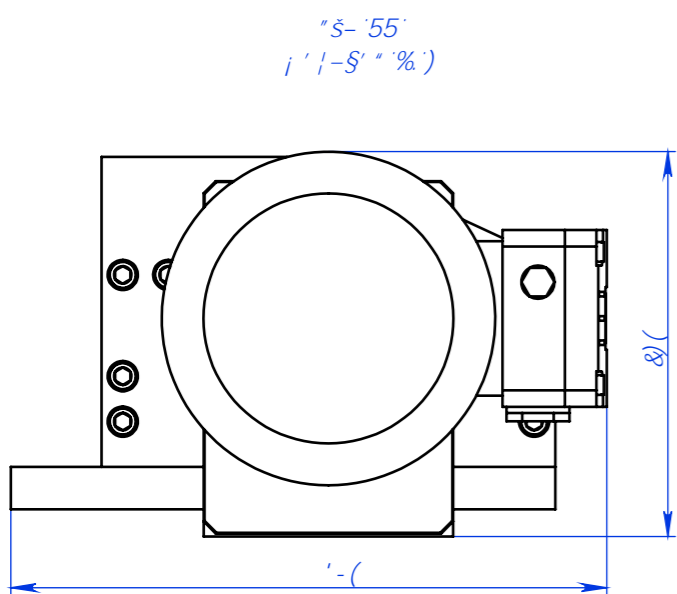
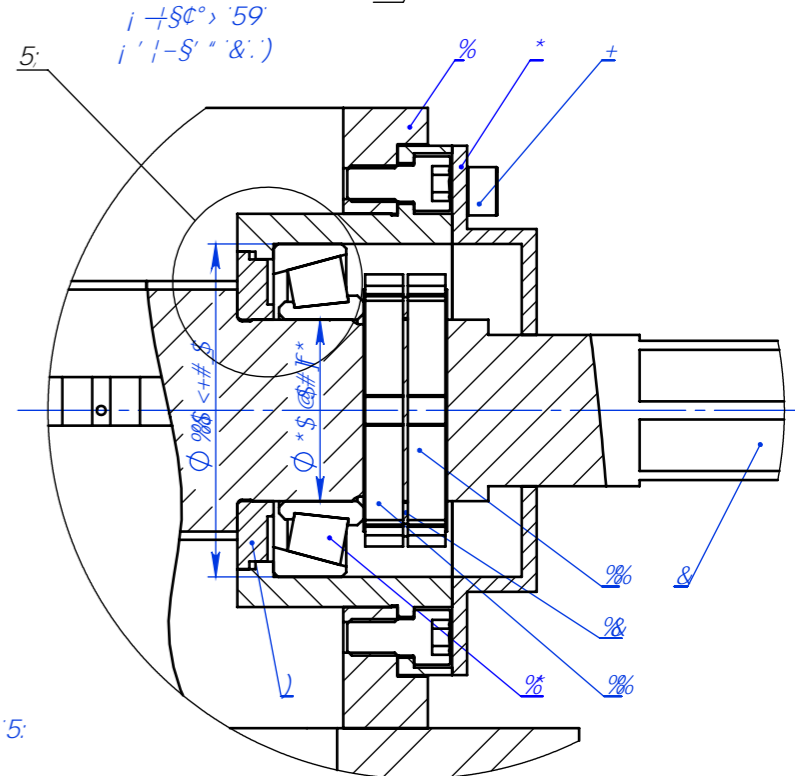
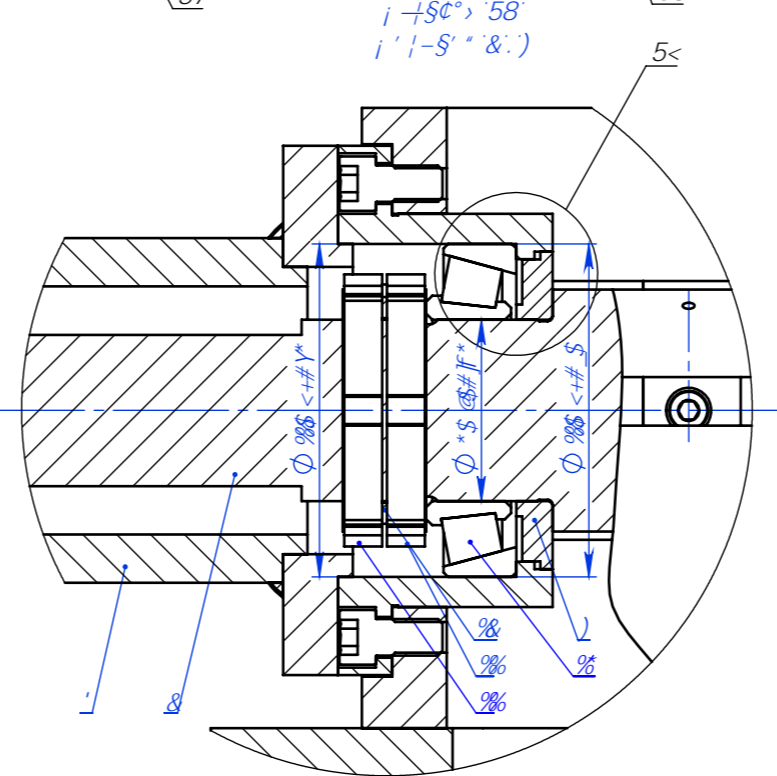
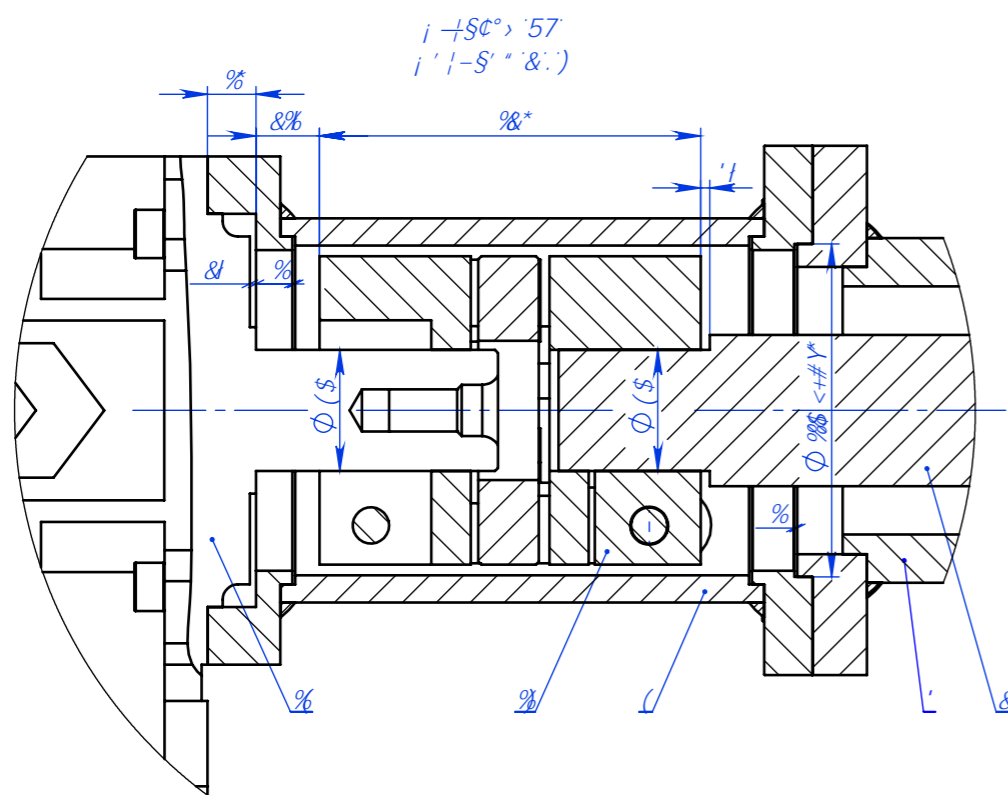
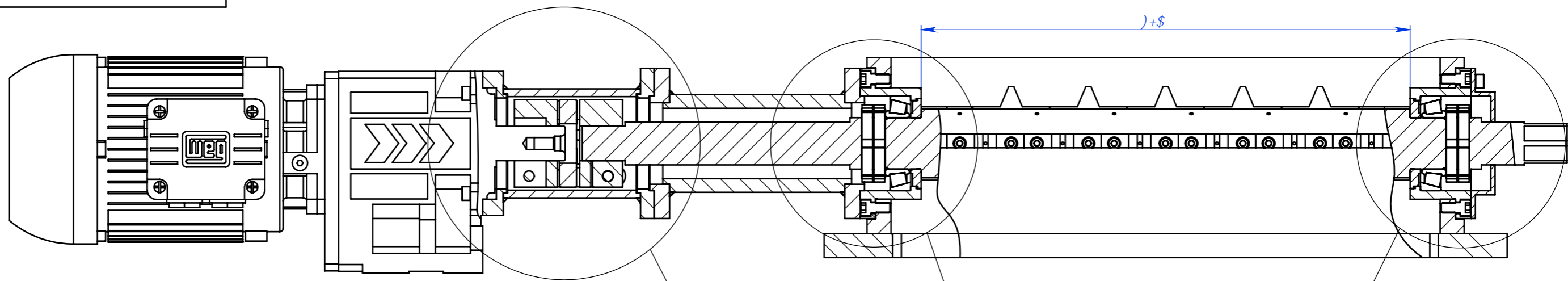

SA BAA'A
 PA'A" 1/2 UCU
 SA B'E'A"
 SA B'E'A"
 " 1/4" A " B
 " 1/4" A " B
 PA'A" 1/2 UCU
 SA BAA'A

SA BAA'A	PA'A" 1/2 UCU	SA B'E'A"	SA B'E'A"	" 1/4" A " B	" 1/4" A " B	PA'A" 1/2 UCU	SA BAA'A
----------	---------------	-----------	-----------	--------------	--------------	---------------	----------

Scē) \$©'; \$* '\$\$\$\$\$' "

Y 1/2
 &

„!\$\$\$\$*\$!, @\$ (æ\$

"s-5>
FAA AAAC %S° L

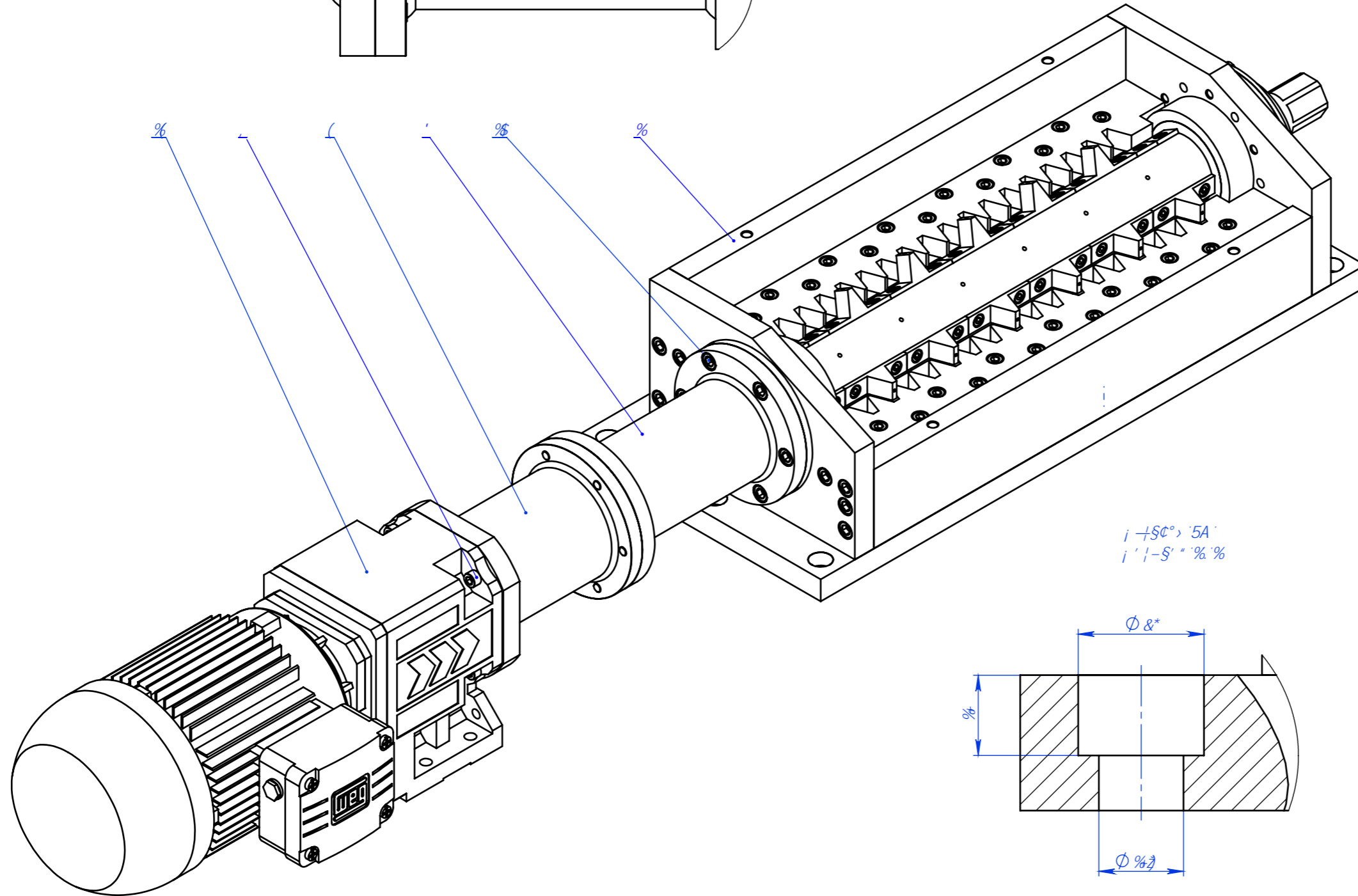
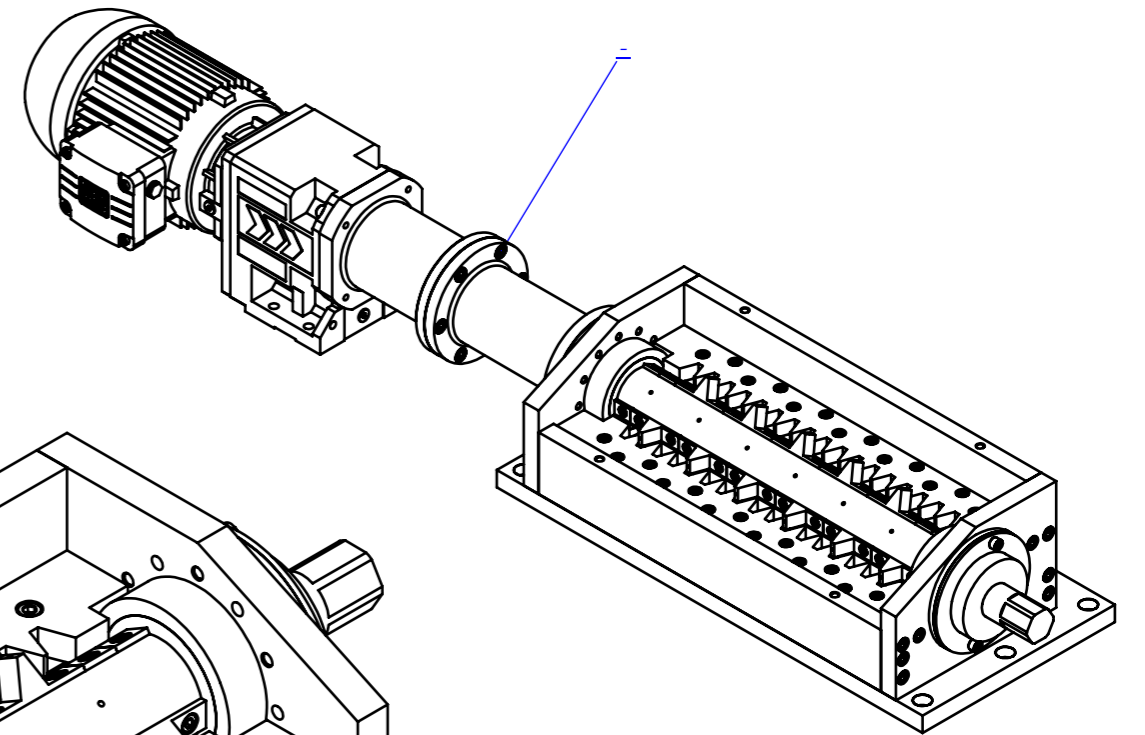
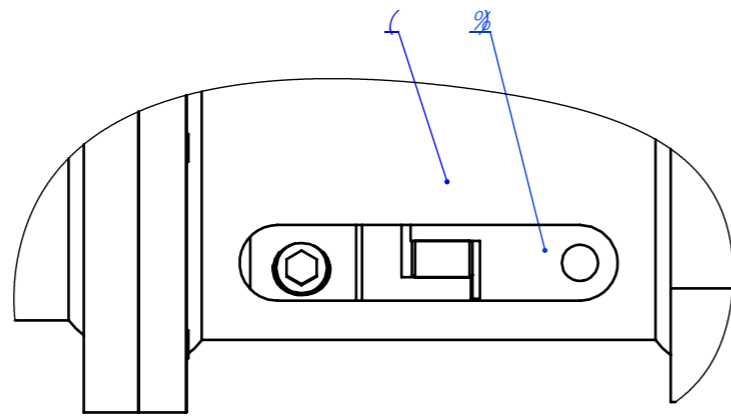

!→\$s-5@5@

!→\$C°> '5A'
! '!'-S' " % %

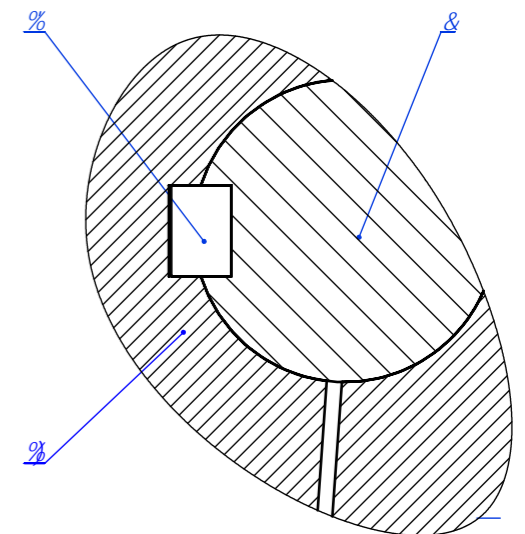
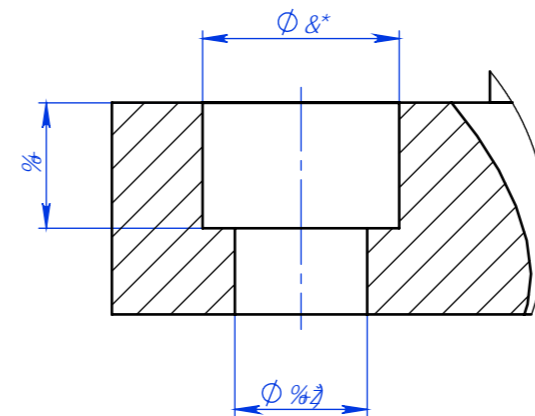

SA BAA'A"	AA'A" 1/2 UCJ	" AA'A" "B	SA "B'EJA"	AA'A" 1/2 UCJ
-----------	---------------	------------	------------	---------------

SA YAE	B'A;EA"	AA'A;AEN -UCJ
--------	---------	---------------

Soe) \$C°; \$* '\$\$\$\$! "

YAE
