

No.	Change	CM-No.	Done	Date
3.0	TRANSLATED	080028	FH	2008-02-26

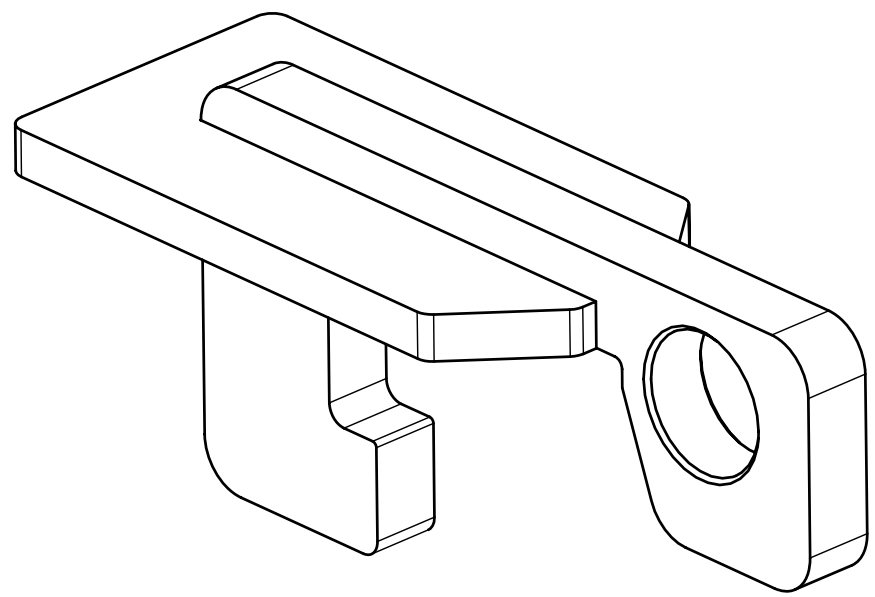
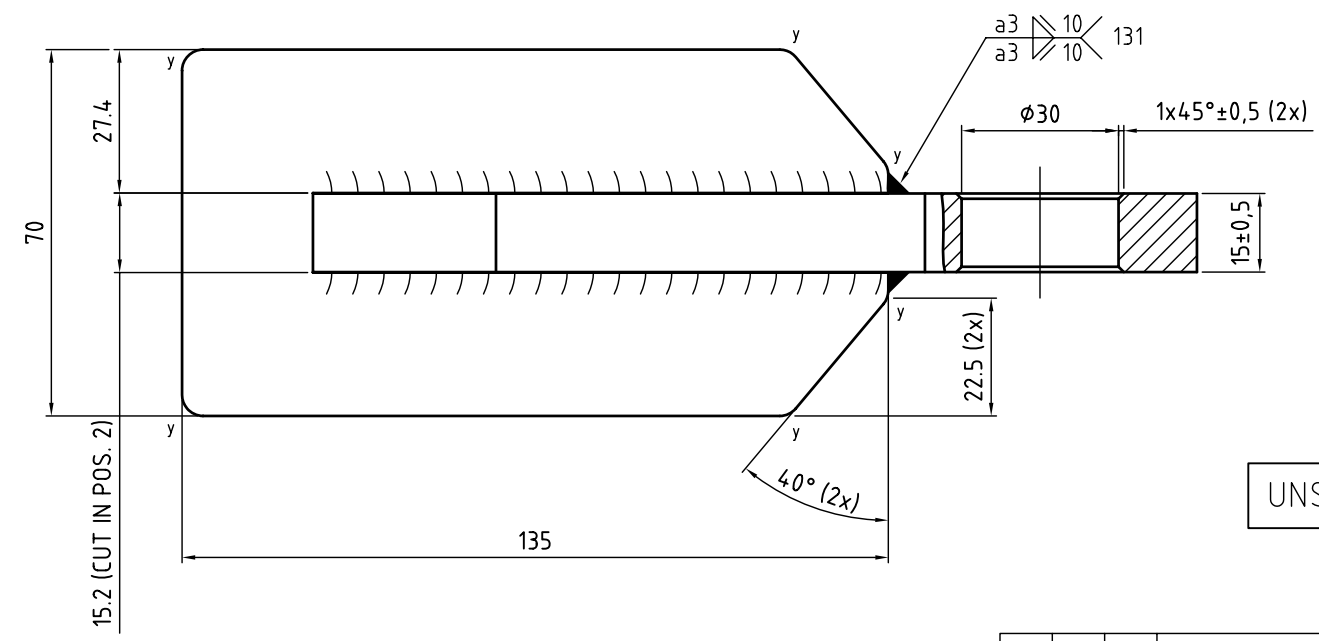
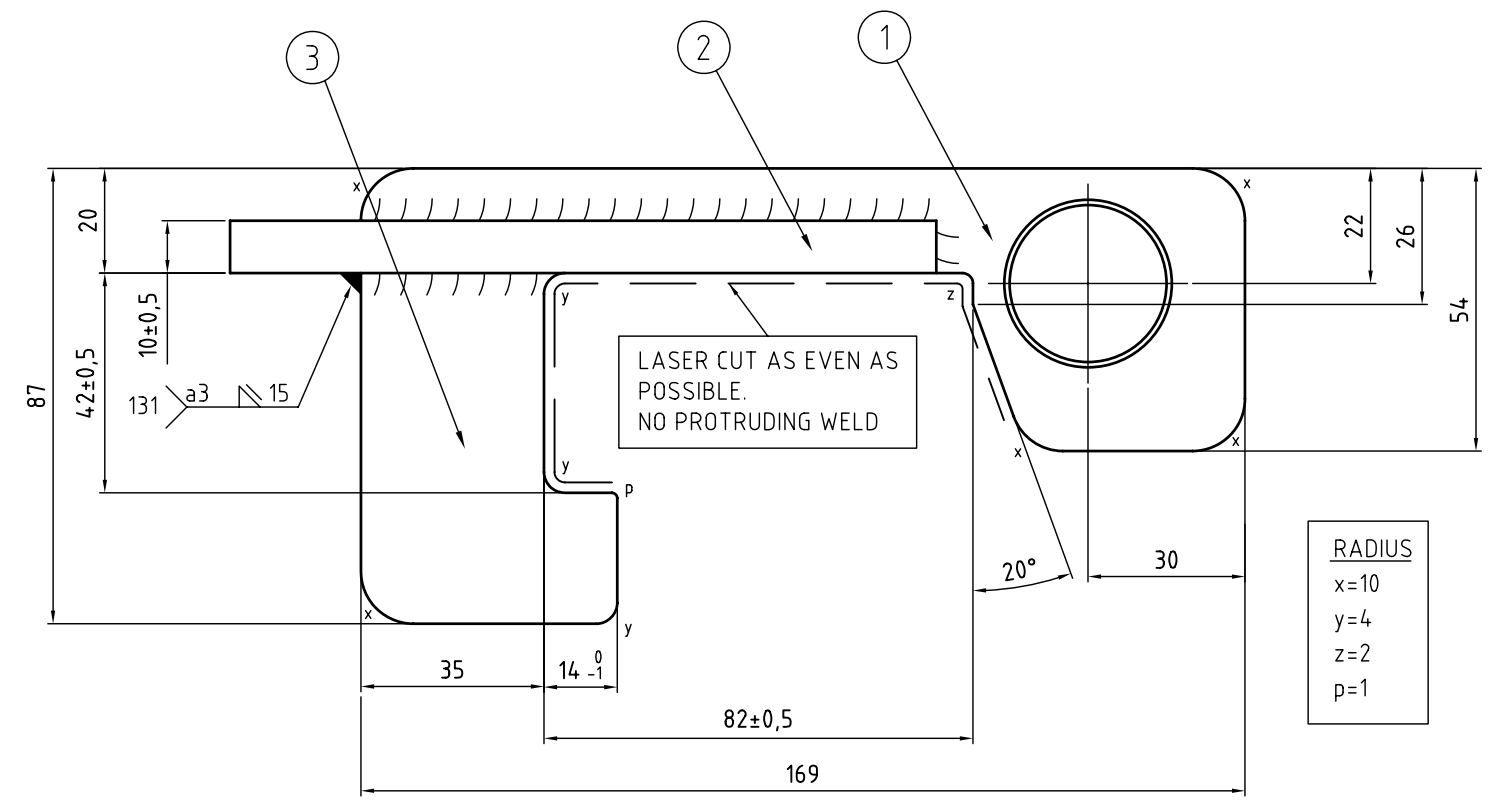
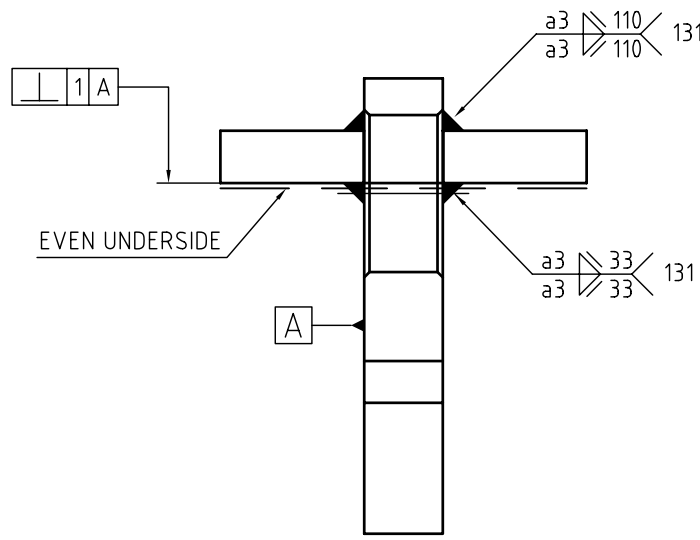

UNSPECIFIED TOLERANCE ±1

WORKING FILE FOR LASEREQUIPMENT: 264309B

3	1	PCS	LABEL LIFTING EQUIPMENT	265765	
2	1	PCS	PLATE (MATERIAL: EN-S275JR)		ALT. DOMEX 240YP
1	1	PCS	PLATE (MATERIAL: EN-S275JR)		ALT. DOMEX 240YP
Item	Qty.	Unit	Description	Art.nr	Remark
Surface treatment PAINT YELLOW RAL 1021				Material	Remark
General tolerance ISO 2768		Proj. method 1:1	Scale 1:1	Drawn TN	Date 1999-10-21
Description LIFTING HOOK TOOL KIT					Status Approved
ASSA ABLOY ASSA ABLOY Entrance Systems AB					Rev. 3.0
					Size A2
					Drawing No. 264309